

**MASCHI A MACCHINA**

MACHINE TAPS - TARAUDS MACHINE

UFS norm

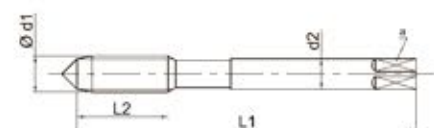

UFS norm

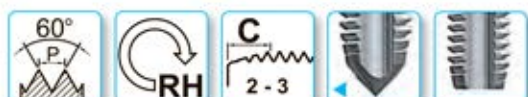
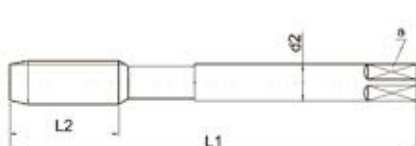

Profond. di filettatura - Thread depth - Profond. de filetage

Materiale - Material - Matériau

Tolleranza - Tolerance - Tolérance

Trattamento superficiale - Surface treatment - Revêtement

 Numero gruppi materiali  
 Material's groups number  
 Nombre de groupes du matériau

LINE



LINE

**1,5xD**
**1,5xD**
**HSSE**
**HSSE**
**2B**
**2B**
**BR**
**TiN**

1.1 1.2 1.3 1.4 3.4

1.1 1.2 1.3 1.4 3.4

4.2 4.3 5.2 5.3

4.2 4.3 5.2 5.3

8.2

8.2

UFS norm	Ød1 UNEF	P TPI	Ø mm	L <sub>1</sub>	L <sub>2</sub>	d <sub>2</sub> h9	a h12	Z	
1/4	32	6,350	80	16	4,5	3,4	3	5,55	
5/16	32	7,938	90	18	6	4,9	3	7,15	
3/8	32	9,525	90	15	7	5,5	3	8,7	
7/16	28	11,113	100	20	8	6,2	3	10,2	
1/2	28	12,700	100	20	9	7	3	11,8	
9/16	24	14,288	100	22	11	9	4	13,2	
5/8	24	15,875	100	22	12	9	4	14,8	
11/16	24	17,462	110	25	14	11	4	16,4	
3/4	20	19,050	110	25	14	11	4	17,8	
13/16	20	20,638	125	25	16	12	4	19,4	
7/8	20	22,225	125	25	18	14,5	4	20,95	
1"	20	25,400	140	28	18	14,5	4	24,15	
1 1/16	18	26,988	140	25	20	16	4	25,6	
1 1/8	18	28,575	150	28	22	18	4	27,15	
1 3/16	18	30,163	150	28	22	18	4	28,75	
1 1/4	18	31,750	150	28	22	18	5	30,3	
1 3/8	18	34,925	170	30	28	22	5	33,5	
1 7/16	18	36,513	170	30	28	22	6	35,1	
1 1/2	18	38,100	170	30	28	22	6	36,7	

CODICE - CODE	
E21UNEF...	E21UNEF...T
○	○
○	○
○	○
○	○
○	○
○	○
○	○
○	○
○	○
○	○
○	○
○	○
○	○
○	○
○	○
○	○
○	○
○	○
○	○
○	○
○	○
○	○

 Confezione: Singola  
 Box: Single  
 Colis: Unique

**€ Pag. listino - Price list - Liste des prix**      **89**      **89**  
 ● Standard      ○ Disponibilità da richiedere, prezzo a listino  
 On enquiry, standard price-list / Stock à vérifier

 ★ Solo a richiesta  
 Only on request / Sur demande

**N** **USO GENERALE**  
General purpose

UFS norm

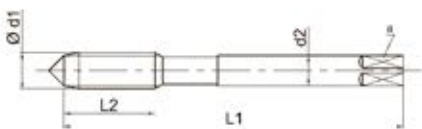

UFS norm

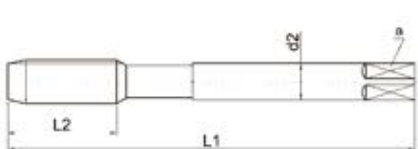

LINE

LINE

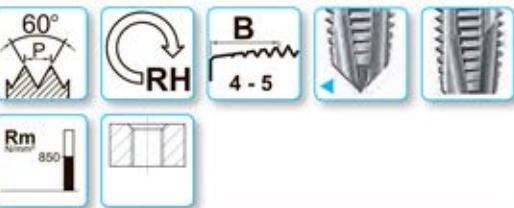

Profond. di filettatura - Thread depth - Profond. de filetage

Materiale - Material - Matériau

Tolleranza - Tolerance - Tolérance

Trattamento superficiale - Surface treatment - Revêtement

3xD	3xD
HSSE	HSSE
2B	2B
<b>BR</b>	<b>TiN</b>
1.1 1.2 1.3 1.4	1.1 1.2 1.3 1.4
4.1 4.2	3.3 3.4
5.1 5.2	4.1 4.2 4.3
	5.1 5.2

Numero gruppi materiali  
Material's groups number  
Nombre de groupes du matériau

UFS norm	Ød1 UNEF	P TPI	Ø mm	L <sub>1</sub>	L <sub>2</sub>	d <sub>2</sub> h9	a h12	Z	Icon
1/4	32	6,350	80	16	4,5	3,4	3	5,55	
5/16	32	7,938	90	18	6	4,9	3	7,15	
3/8	32	9,525	90	15	7	5,5	3	8,7	
7/16	28	11,113	100	20	8	6,2	3	10,2	
1/2	28	12,700	100	20	9	7	3	11,8	
9/16	24	14,288	100	22	11	9	4	13,2	
5/8	24	15,875	100	22	12	9	4	14,8	
11/16	24	17,462	110	25	14	11	4	16,4	
3/4	20	19,050	110	25	14	11	4	17,8	
13/16	20	20,638	125	25	16	12	4	19,4	
7/8	20	22,225	125	25	18	14,5	4	20,95	
1"	20	25,400	140	28	18	14,5	4	24,15	
1 1/16	18	26,988	140	25	20	16	4	25,6	
1 1/8	18	28,575	150	28	22	18	4	27,15	
1 3/16	18	30,163	150	28	22	18	4	28,75	
1 1/4	18	31,750	150	28	22	18	5	30,3	
1 3/8	18	34,925	170	30	28	22	5	33,5	
1 7/16	18	36,513	170	30	28	22	6	35,1	
1 1/2	18	38,100	170	30	28	22	6	36,7	

CODICE - CODE	
E2SUNEF...	E2SUNEF...T
○	○
○	○
○	○
○	○
○	○
○	○
○	○
○	○
○	○
○	○
○	○
○	○
○	○
○	○
○	○
○	○
○	○
○	○
○	○
○	○
○	○

UNEF

## MASCHI A MACCHINA

### MACHINE TAPS - TARAUDS MACHINE

N

USO GENERALE

General purpose - Usage Général

UFS norm

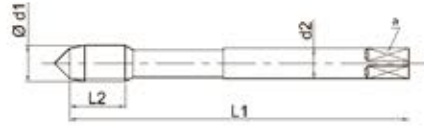

UFS norm

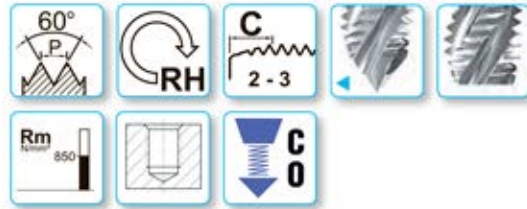
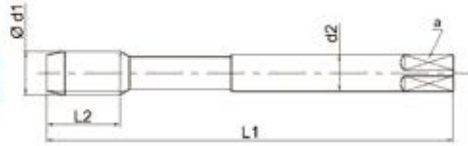

Profond. di filettatura - Thread depth - Profond. de filetage

Materiale - Material - Matériau

Tolleranza - Tolerance - Tolérance

Trattamento superficiale - Surface treatment - Revêtement

2,5xD

HSSE

2B

BR

1.1 1.2 1.3 1.4

4.1 4.2

5.1 5.2

2,5xD

HSSE

2B

XP

1.1 1.2 1.3 1.4

2.1 2.2 3.3 3.4

4.2 4.3

5.2

Numero gruppi materiali  
Material's groups number  
Nombre de groupes du matériau

UFS norm	Ød1	P	Ø	L <sub>1</sub>	L <sub>2</sub>	d <sub>2</sub> h9	a h12	Z	
UNEf	TPI		mm						
1/4	32	6,350	80	10	4,5	3,4	3	5,55	
5/16	32	7,938	90	13	6	4,9	3	7,15	
3/8	32	9,525	90	15	7	5,5	3	8,7	
7/16	28	11,113	100	15	8	6,2	3	10,2	
1/2	28	12,700	100	13	9	7	3	11,8	
9/16	24	14,288	100	15	11	9	4	13,2	
5/8	24	15,875	100	15	12	9	4	14,8	
11/16	24	17,462	110	17	14	11	4	16,4	
3/4	20	19,050	110	17	14	11	4	17,8	
13/16	20	20,638	125	18	16	12	4	19,4	
7/8	20	22,225	125	18	18	14,5	4	20,95	
1"	20	25,400	140	22	18	14,5	4	24,15	
1 1/16	18	26,988	140	20	20	16	4	25,6	
1 1/8	18	28,575	150	22	22	18	4	27,15	
1 3/16	18	30,163	150	22	22	18	4	28,75	
1 1/4	18	31,750	150	22	22	18	5	30,3	
1 3/8	18	34,925	170	24	28	22	5	33,5	
1 7/16	18	36,513	170	24	28	22	6	35,1	
1 1/2	18	38,100	170	24	28	22	6	36,7	

CODICE - CODE	
E61UNEf...	E61UNEf...XP
○	○
○	○
○	○
○	○
○	○
○	○
○	○
○	○
○	○
○	○
○	○
○	○
○	○
○	○
○	○
○	○
○	○
○	○
○	○

Confezione: Singola  
Box: Single  
Colis: Unique

€ Pag. listino - Price list - Liste des prix  
• Standard

89  
○ Disponibilità da richiedere, prezzo a listino  
On enquiry, standard price-list / Stock à vérifier

89  
★ Solo a richiesta  
Only on request / Sur demande

N

**USO GENERALE**

General purpose - Usage Général

**MASCHI A MACCHINA**

MACHINE TAPS - TARAUDS MACHINE

UFS norm

UFS norm

UFS norm

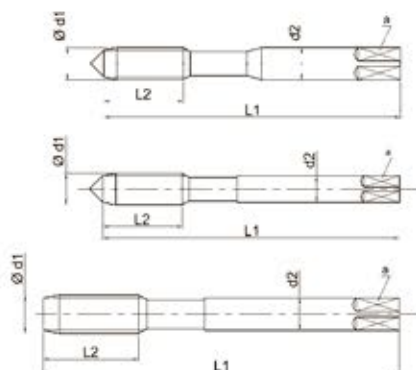

LINE

LINE



60° P.P. RH C 2-3

Rm 850

Profond. di filettatura - Thread depth - Profond. de filetage

Materiale - Material - Matériau

Tolleranza - Tolerance - Tolérance

Trattamento superficiale - Surface treatment - Revêtement

Numero gruppi materiali  
 Material's groups number  
 Nombre de groupes du matériau

1,5xD	1,5xD
HSSE	HSSE
2B	2B
BR	TiN
1.1 1.2 1.3 1.4 3.4	1.1 1.2 1.3 1.4 3.4
4.2 4.3 5.2 5.3	4.2 4.3 5.2 5.3
8.2	8.2

UFS norm	Ød1 UNS	P TPI	Ø mm	L1	L2	d2 h9	a h12	Z	
◀	10	40	4,826	70	13	6	4,9	3	4,2
◀	10	48	4,826	70	13	6	4,9	3	4,3
◀	12	36	5,486	80	16	6	4,9	3	4,8
◀	1/4	24	6,350	80	16	7	5,5	3	5,3
◀	1/4	36	6,350	80	16	7	5,5	3	5,6
◀	1/4	40	6,350	80	16	7	5,5	3	5,7

CODICE - CODE	
E20-...UNS...	E20-...UNS...T
◊	◊
◊	◊
◊	◊
◊	◊
◊	◊

UFS norm	Ød1 UNS	P TPI	Ø mm	L1	L2	d2 h9	a h12	Z	
◀	5/16	40	7,938	90	18	6	4,9	3	7,3
◀	3/8	18	9,525	100	20	7	5,5	3	8,1
◀	3/8	27	9,525	90	15	7	5,5	3	8,6
◀	3/8	40	9,525	90	15	7	5,5	3	8,9
	7/16	24	11,113	100	20	8	6,2	3	10,05
	7/16	27	11,113	100	20	8	6,2	3	10,2
	1/2	24	12,700	100	20	9	7	3	11,6
	1/2	27	12,700	100	20	9	7	3	11,75
	5/8	27	15,875	100	22	12	9	4	14,9
	11/16	18	17,462	110	25	14	11	4	16,05
	3/4	18	19,050	110	25	14	11	4	17,6
	7/8	18	22,225	125	25	18	14,5	4	20,8
	7/8	24	22,225	125	25	18	14,5	4	21,2
	15/16	18	23,813	140	25	18	14,5	4	22,4
	1"	14	25,400	140	28	18	14,5	4	23,6
	1"	18	25,400	140	28	18	14,5	4	24
	1"	24	25,400	140	28	18	14,5	4	24,3
	1 1/4	14	31,750	150	28	22	18	5	29,9
	1 5/16	14	33,338	170	30	28	22	5	31,5

CODICE - CODE	
E21-...UNS...	E21-...UNS...T
◊	◊
◊	◊
◊	◊
◊	◊
◊	◊
◊	◊
◊	◊
◊	◊
◊	◊
◊	◊
◊	◊
◊	◊
◊	◊
◊	◊
◊	◊
◊	◊
◊	◊
◊	◊
◊	◊
◊	◊
◊	◊
◊	◊

UNS

N

USO GENERALE

General purpose - Usage Général

MASCHI A MACCHINA

MACHINE TAPS - TARAUDS MACHINE

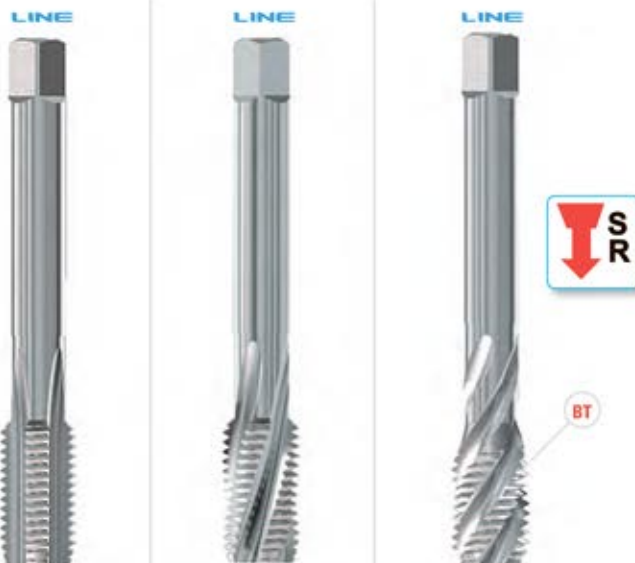
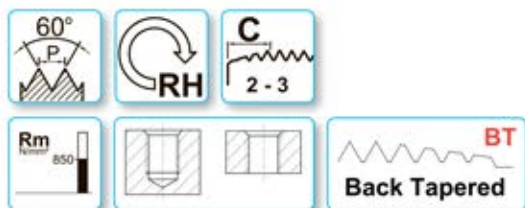
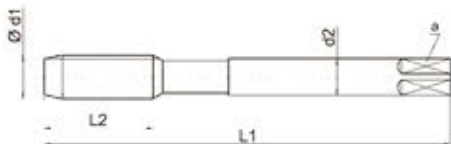

Profond. di filettatura - Thread depth - Profond. de filetage	1,5xD	1,5xD	2,5xD
Materiale - Material - Matériau	HSSE	HSSE	HSSE
Tolleranza - Tolerance - Tolérance	2B	2B	2B
Trattamento superficiale - Surface treatment - Revêtement	BR	BR	BR
Numero gruppi materiali Material's groups number Nombre de groupes du matériau	1.1 1.2 1.3 1.4 3.4 4.2 4.3 5.2 5.3 8.2	1.1 1.2 1.3 1.4 3.4 4.2 4.3 5.2 5.3 8.2	1.1 1.2 1.3 1.4 3.4 4.2 4.3 5.2 5.3 8.2

DIN 2184-1	Ød1	P	Ø	L1	L2	d2	a	Z	Icon
8-UN	TPI	mm				h9	h12		
1"1/8	8	28,575	180	40	22	18	4	25,4	
1"1/4	8	31,750	180	40	22	18	4	28,6	
1"3/8	8	34,925	200	50	28	22	4	31,75	
1"1/2	8	38,100	200	50	28	22	4	34,9	
1"5/8	8	41,275	200	50	32	24	5	38,1	
1"3/4	8	44,450	200	50	36	29	5	41,3	
1"7/8	8	47,625	225	60	36	29	5	44,45	
2"	8	50,800	225	60	40	32	5	47,6	
2"1/4	8	57,150	250	65	45	35	6	54	
2"1/2	8	63,500	275	70	50	39	6	60,3	

UFS norm	Ød1	P	Ø	L1	L2	d2	a	Z	Icon
12-UN	TPI	mm				h9	h12		
7/8	12	22,225	125	25	18	14,5	4	20,1	
1"1/16	12	26,988	140	25	20	16	4	24,9	
1"3/16	12	30,163	150	28	22	18	4	28	
1"5/16	12	33,338	170	30	28	22	5	31,2	
1"7/16	12	36,513	170	30	28	22	6	34,4	
1"5/8	12	41,275	170	30	32	24	6	39,2	
1"3/4	12	44,450	180	32	36	29	6	42,3	
2"	12	50,8	190	32	40	32	6	48,7	

UFS norm	Ød1	P	Ø	L1	L2	d2	a	Z	Icon
16-UN	TPI	mm				h9	h12		
1"	16	25,400	140	28	18	14,5	4	23,8	
1"1/8	16	28,575	150	28	22	18	4	27	
1"1/4	16	31,750	150	28	22	18	5	30,15	
1"1/2	16	38,100	170	30	28	22	6	36,5	
2"	16	50,8	190	32	40	32	6	49,2	

CODICE - CODE		
E21-8UN...	E41-8UN...	E81-8UN...
○	○	○
○	○	○
○	○	○
○	○ (Z=5)	○ (Z=5)
○	○	○
○	○	○
○	○	○
○	○	○
○	○	○
○	○	○

CODICE - CODE		
E21-12UN...		
○		
○		
○		
○		
○		
○		
○		
○		

CODICE - CODE		
E21-16UN...		
○		
○		
○		
○		

RACCOMANDATO per filettatura rigida  
We recommend Syncro rigid threading  
Recommandé pour le taraudage rigide



■ = Acciaio HSS / HSS Steel / Acier HSS

Confezione: Singola Box: Single Colis: Unique	€ Pag. listino - Price list - Liste des prix	91	91	91
● Standard	○ Disponibilità da richiedere, prezzo a listino On enquiry, standard price-list / Stock à vérifier	★ Solo a richiesta Only on request / Sur demande		

**N** **USO GENERALE**  
 General purpose - Usage Général

**MASCHI A MACCHINA**  
 MACHINE TAPS - TARAUDS MACHINE

UFS norm

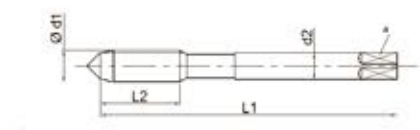

UFS norm

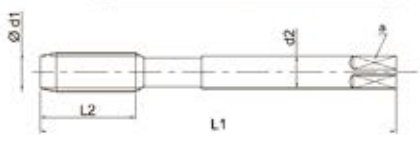

60° J.P. RH C 2-3

Rm 850

LINE



LINE



Profond. di filettatura - Thread depth - Profond. de filetage

Materiale - Material - Matériau

Tolleranza - Tolerance - Tolérance

Trattamento superficiale - Surface treatment - Revêtement

Numero gruppi materiali  
 Material's groups number  
 Nombre de groupes du matériau

1,5xD	1,5xD
HSSE	HSSE
2B	2B
BR	TiN
1.1 1.2 1.3 1.4 3.4	1.1 1.2 1.3 1.4 3.4
4.2 4.3 5.2 5.3	4.2 4.3 5.2 5.3
8.2	8.2

UFS norm	Ød1	P	Ø	L <sub>1</sub>	L <sub>2</sub>	d <sub>2</sub>	a	Z	
	20-UN	TPI	mm			h9	h12		
◀	3/8	20	9,525	100	20	7	5,5	3	8,3
	5/8	20	15,875	100	22	12	9	4	14,6
	1"1/16	20	26,988	140	25	20	16	4	25,7
	1"1/8	20	28,575	150	28	22	18	4	27,3
	1"1/4	20	31,750	150	28	22	18	5	30,5
	1"3/8	20	34,925	170	30	28	22	5	33,7

CODICE - CODE	
E21-20UN...	E21-20UN...T
◊	◊
◊	◊
◊	◊
◊	◊
◊	◊

UFS norm	Ød1	P	Ø	L <sub>1</sub>	L <sub>2</sub>	d <sub>2</sub>	a	Z	
	28-UN	TPI	mm			h9	h12		
◀	3/8	28	9,525	90	15	7	5,5	3	8,6
	5/8	28	15,875	100	22	12	9	4	15

CODICE - CODE	
E21-28UN...	E21-28UN...T
◊	◊
◊	◊

UFS norm	Ød1	P	Ø	L <sub>1</sub>	L <sub>2</sub>	d <sub>2</sub>	a	Z	
	32-UN	TPI	mm			h9	h12		
	7/16	32	11,113	100	20	8	6,2	3	10,3
	1/2	32	12,700	100	20	9	7	3	11,9

CODICE - CODE	
E21-32UN...	E21-32UN...T
◊	◊
◊	◊

Confezione: Singola  
 Box: Single  
 Collis: Unique

€ Pag. listino - Price list - Liste des prix **91** **91**

• Standard

◊ Disponibilità da richiedere, prezzo a listino  
 On enquiry, standard price-list / Stock à vérifier

★ Solo a richiesta  
 Only on request / Sur demande

UN...

## CALIBRI FILETTATI

## THREAD GAUGES - CALIBRES DE FILETAGE

ANSI / ASME B1.2

### Calibri a tampone filettati passa / non passa

Thread plug gauges go/no-go

Calibres de filetage entre/n'entre pas



Tolleranza - Tolerance - Tolérance

2B

Trattamento superficiale - Surface treatment - Revêtement

BR

Ød1 UNEf	TPI	CODICE - CODE P-NPUNEf...
1/4	32	0
5/16	32	0
3/8	32	0
7/16	28	0
1/2	28	0
9/16	24	0
5/8	24	0
11/16	24	0
3/4	20	0
13/16	20	0
7/8	20	0
1"	20	0
1" 1/16	18	0
1" 1/8	18	0
1" 3/16	18	0
1" 1/4	18	0
1" 3/8	18	0
1" 7/16	18	0
1" 1/2	18	0

A richiesta sono eseguibili i seguenti tamponi:  
On request we can provide the following gauges:  
Sur demande les tampons suivants:

UNS  
8-UN  
12-UN  
16-UN  
20-UN  
28-UN  
32-UN

Confezione / Box / Colis:  
M3 – M10: 10 pezzi / pcs  
M12 – M16: 5 pezzi / pcs

€ Pag. listino - Price list - Liste des prix

• Standard

○ Disponibilità da richiedere, prezzo a listino  
On enquiry, standard price-list / Stock à vérifier

109

★ Solo a richiesta  
Only on request / Sur demande